

OEI no: OEI800003677

## Road Condition Sensors (RCS) SHAKE



Product group	Electrics and Electronics
Voltage	9-16V
Additional information	Minimum detection limit (road wetness) 250 μm, Interface LIN 2.1

Manufacturer: Hella

Size (mm): 56x29

Model: (RCS) SHAKE

Power: ~ 20 mA at 12 V

IP Rating: IP69K

Shape: Other

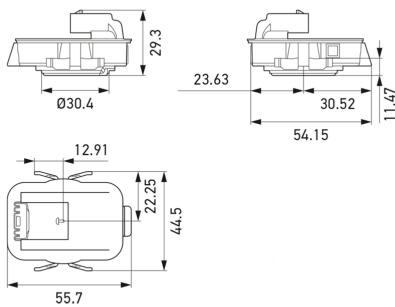

### APPLICATION

